

**TL | TOUGHLIFT JACKING SYSTEMS**



- ▶ Choice of air or electric driven hydraulic system
- ▶ High flow 3-stage pump unit offers faster advance and retract times
- ▶ Solid tyres fitted as standard with option of pneumatic tyres
- ▶ Narrow width wheels and redesigned wheel position for better ground clearance and balance when manoeuvring
- ▶ Push button remote hand pendant controller with 5 metres control cable
- ▶ Tilting saddles fitted as standard on all models
- ▶ User friendly design with easily accessible maintenance features
- ▶ Wide range of accessories available for even greater versatility see pages 73 and 74

**Choice of 8 models with capacities from 50 to 200 tonnes**

**Lifting heights up to 685 mm**

**Working pressure 700 bar**

**Dimensions for 50 tonne models:**

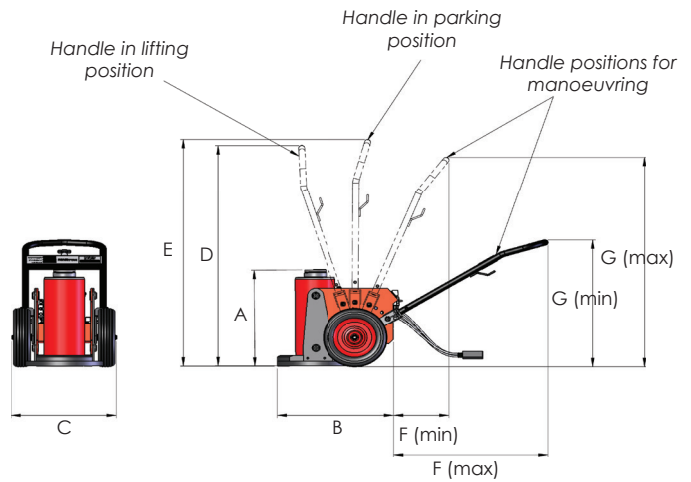

**Dimensions for all other models:**

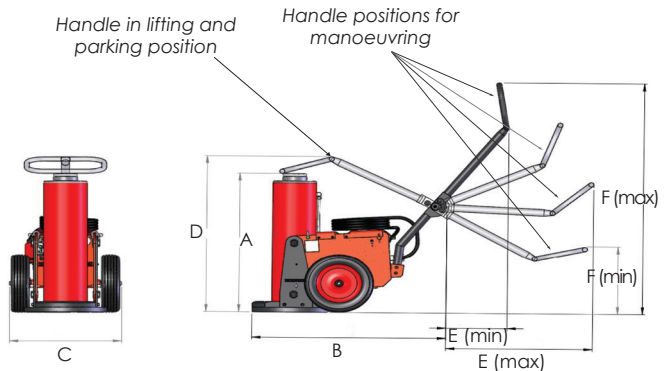

Model number	Capacity (tonnes)	Power supply	Stroke (mm)	Weight (kg)	Max additional stack in (mm)	Dimensions (mm)						
						A	B	C	D	E (min-max)	F (min-max)	G (min-max)
TL050A255	50	6-bar air driven	254	160	680	455	660	560	1440	1440	380 - 1000	700 - 1300
TL050E255	50	240V electric	254	168	680	455	660	560	1440	1440	380 - 1000	700 - 1300
TLA10016	100	6-bar air driven	405	289	480	665	1130	652	831	356 - 854	465 - 1605	-
TLA10021	100	6-bar air driven	530	319	180	843	1130	652	946	356 - 854	465 - 1605	-
TLA15015	150	6-bar air driven	390	313	485	665	1130	652	835	356 - 854	465 - 1605	-
TLA15020	150	6-bar air driven	520	349	180	843	1130	652	963	356 - 854	465 - 1605	-
TLA20015	200	6-bar air driven	381	373	500	660	1130	652	830	356 - 854	465 - 1605	-
TLA20027	200	6-bar air driven	685	453	180	964	1130	652	1085	356 - 854	465 - 1605	-

*Note: 100, 150 and 200 tonne electric driven Hi-Force ToughLift jacking systems available on request*