

**MHX-PU | MANUALLY OPERATED HYDROTEST PUMP UNITS**



Choice of 5 models available

Maximum output pressures up to 1000 bar

Two stage displacement with manual T-Handle changeover plunger

- ▶ Supplied as pump unit and operating lever only, reservoir not included
- ▶ Includes four bolt fixing kit with gasket for easy mounting on fluid reservoir
- ▶ All other features are as specified for the MXH pumps

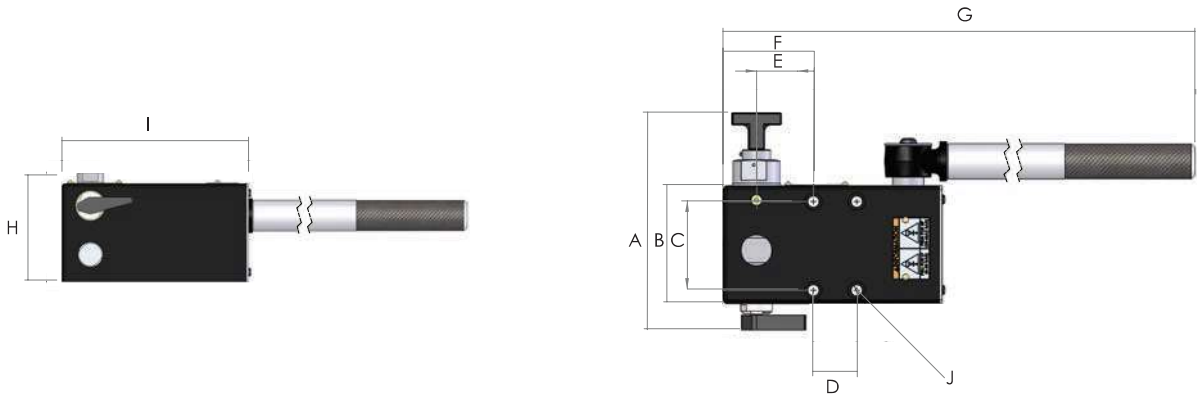

Model number (pump only)	Working pressure (bar)	Valve type	Displacement per stroke (cm <sup>3</sup> )		Changeover pressure (bar)	Outlet port	Suction port	Weight (kg)
			1 <sup>st</sup> stage	2 <sup>nd</sup> stage				
MHX100PU	100	2-way	50	22	50	3/8" NPT	3/8" NPT	5
MHX300PU	300	2-way	50	8	50	3/8" NPT	3/8" NPT	5
MHX500PU	500	2-way	50	4	50	3/8" NPT	3/8" NPT	5
MHX700PU	700	2-way	50	3	50	3/8" NPT	3/8" NPT	5
MHX1000PU	1000	2-way	50	2	50	3/8" BSP	3/8" NPT	5

Model number	Dimensions (mm)									
	A	B	C	D	E	F	G	H	I	J
All models	180	95	71.5	35	46	69	760	105	177	4 X M8

**RESERVOIR**



Model number	Description
MHR15	15 litre standard reservoir