

HGG | SINGLE ACTING LOAD RETURN HIGH TONNAGE INDUSTRIAL CYLINDERS



Capacities from 152 to 326 tonnes

Stroke length 155 mm

Working pressure 700 bar

- ▶ Single acting, load return
- ▶ Heavy duty design for lifting and maintenance applications
- ▶ Integral stop ring for piston stroke limitation
- ▶ Tilting saddle fitted as standard to reduce the risk of side loading
- ▶ Low friction bearing surfaces
- ▶ Nitrocarburised piston rod for corrosion resistance
- ▶ Anti-extrusion seals for improved performance at high pressures
- ▶ Saddle and piston rod details are listed on pages 24 and 25

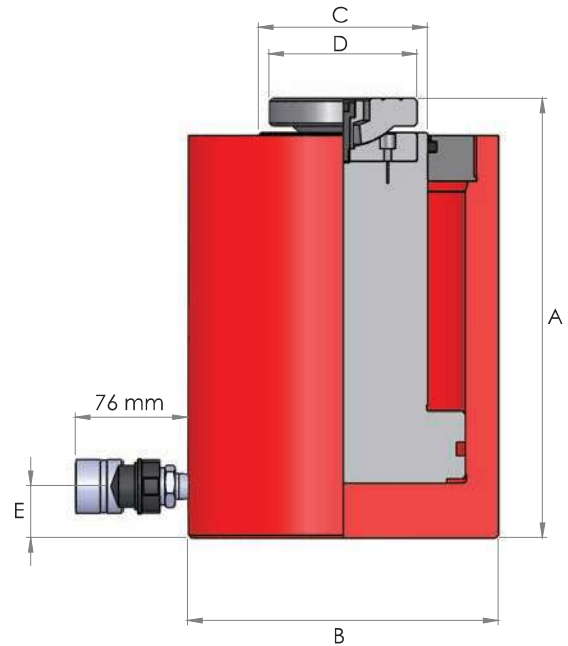

Model number	Capacity (tonnes)	Stroke (mm)	Oil capacity (litres)	Cylinder eff. area (cm ²)	Weight (kg)	Dimensions (mm)				
						A	B	C	D	E
HGG1506	152	155	3.32	214.3	58.3	297	210	114	100	37
HGG2006	203	155	4.63	285.1	95.3	310	254	140	135	50
HGG3006	326	155	7.10	457.7	153.5	343	312	165	150	50